

REBUILT GAME PLAY 2026

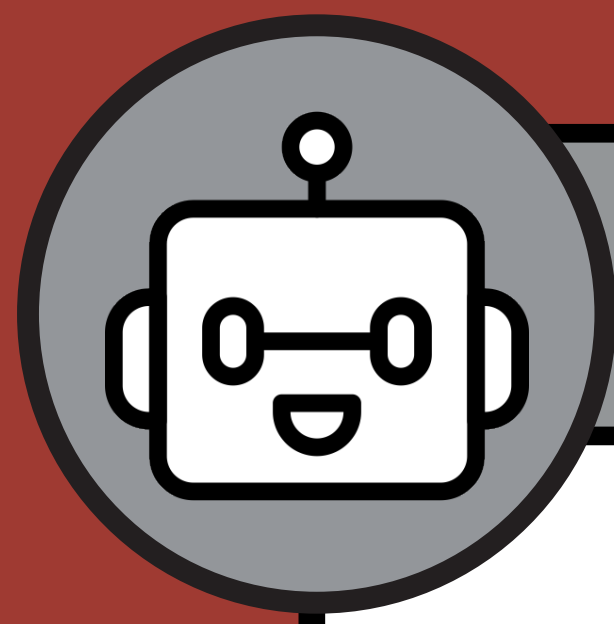

AUTONOMOUS Code Driven

FIRST 20 SECONDS OF THE MATCH

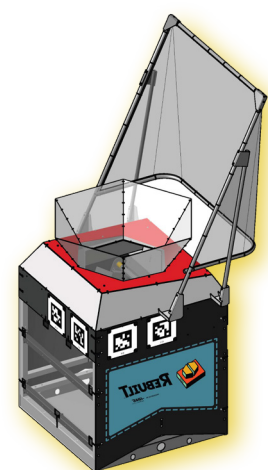

- **BOTH** Hubs are **ACTIVE** (lit up & able to score)
- Robots can be pre-loaded with 8 fuel.
- Most points determines which 2 shifts each alliance has their hub activated during Teleop period (see below).
- Buzzer signals end of auto period.



FUEL: 1 point for each scored in the hub.

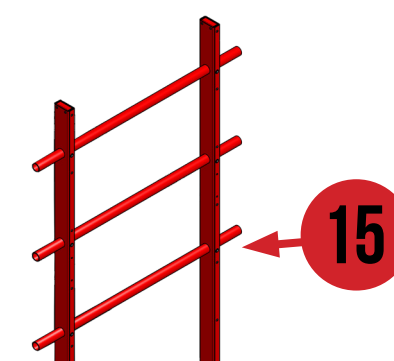

TOWER: up to 2 robots can climb for a max of 15 points each.



TELEOP Human Driven

REMAINDER OF THE MATCH IS SPLIT INTO 6 SHIFTS:

TRANSITION SHIFT

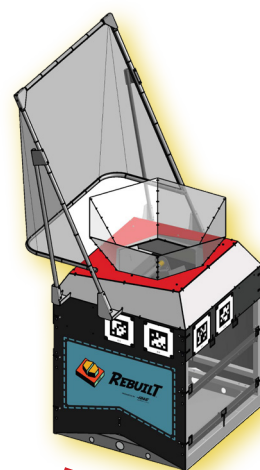

- Hub is active for **BOTH** alliances to score fuel.
- Team with the **LEAST AUTO** points will be first to have their hub active in alliance shift 1.



FUEL: 1 point for each scored in the hub.

ALLIANCE SHIFT 1



- Hubs take turns being active during the 4 alliance shifts. (Which team's hub is active depends on who got the most/least points in auto.)



FUEL: 1 point for each scored in their activated hubs.

ALLIANCE SHIFT 2



- The team with an **ACTIVE** hub can score points by shooting fuel into their hub.



ENERGIZED RANKING POINTS: Go to the team(s) who score 100 fuel*.

ALLIANCE SHIFT 3



- The teams with an **INACTIVE** hub can play defense & gather fuel.



SUPERCHARGED RANKING POINTS: Go to the team(s) who score 360 fuel*.

ALLIANCE SHIFT 4



*Points thresholds are subject to change as the season progresses

END GAME

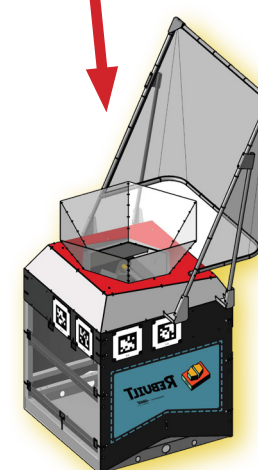

- Hub is **ACTIVE** for **BOTH** alliances to score.
- Robots can earn points by climbing the tower.

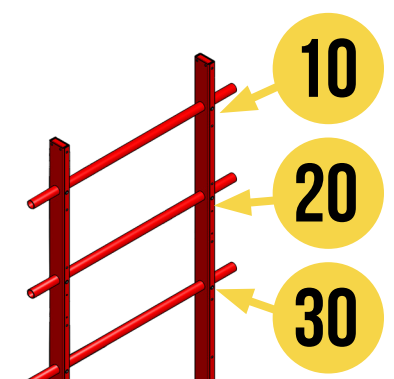

TOWER: Points awarded based on which level the robot reaches at the end of the match.



AFTER THE MATCH

Final ranking points are awarded after the match ends.

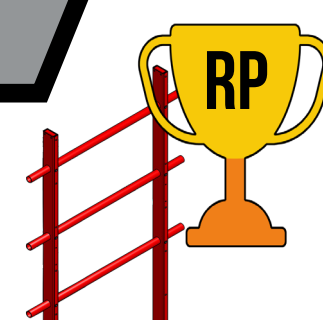

TRAVERSAL RANKING POINT: Goes to the teams who earn **50 points** on the tower during auto & end game.



WINNER RANKING POINT: 3 ranking points go to the teams on the winning alliance for the match, or 1 ranking point for a tie.

REBUILT GAME ELEMENTS 2026

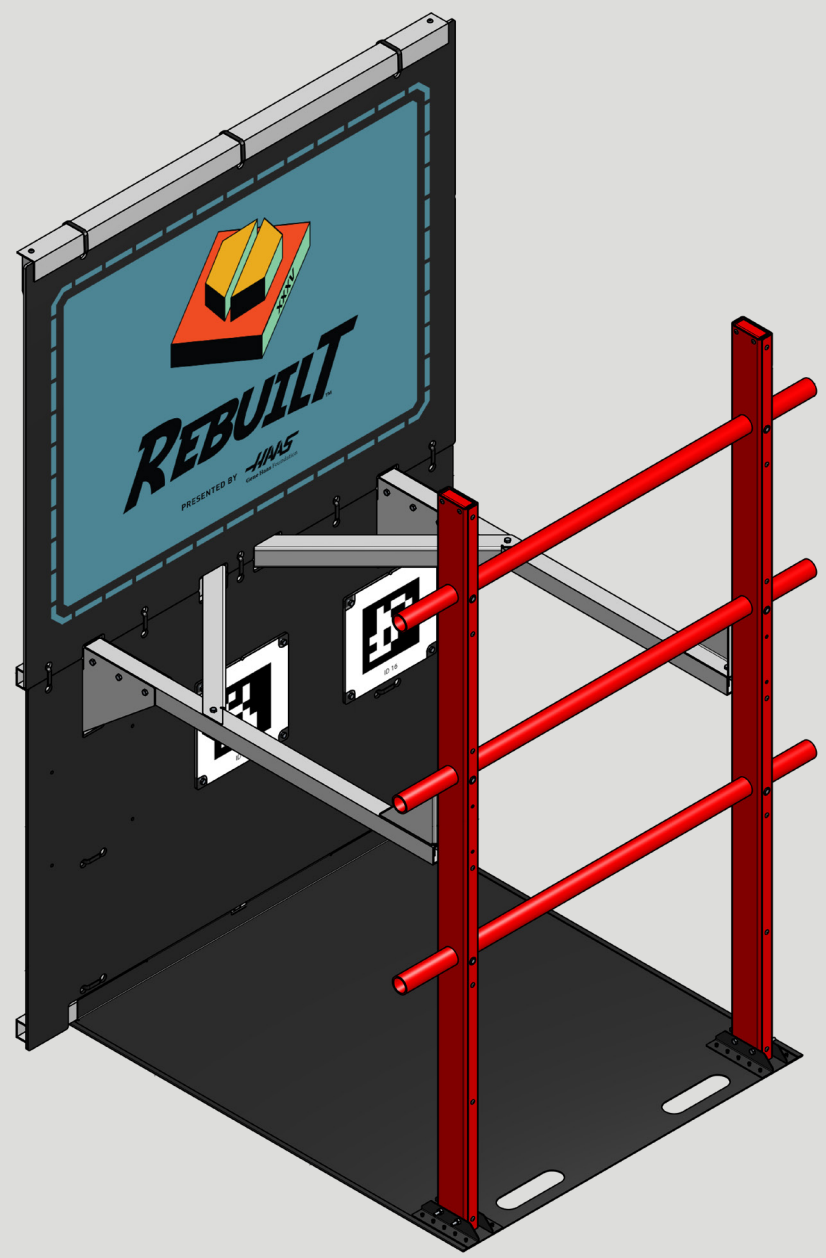

TOWER: Can climb in Auto on first run for 15 points (2 Robots Max)

Endgame: Rung 1 (bottom) is 10 points, Rung 2 (middle) is 20 points, Rung 3 (top) is 30 points.

TRENCH: The Trench has a 22" clearance that robots can drive under.

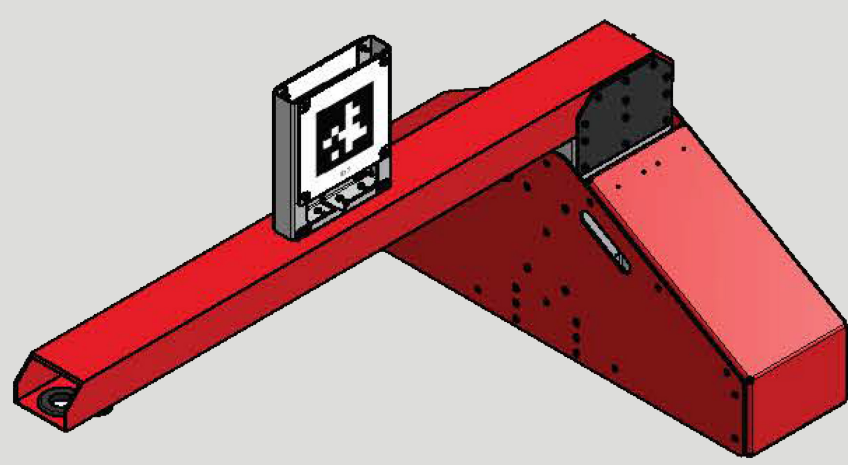

TRENCH

OUTPOST: Collects balls that the Human Player can throw into the Hub or drop using the arm into the robot. They can also drop one at time.

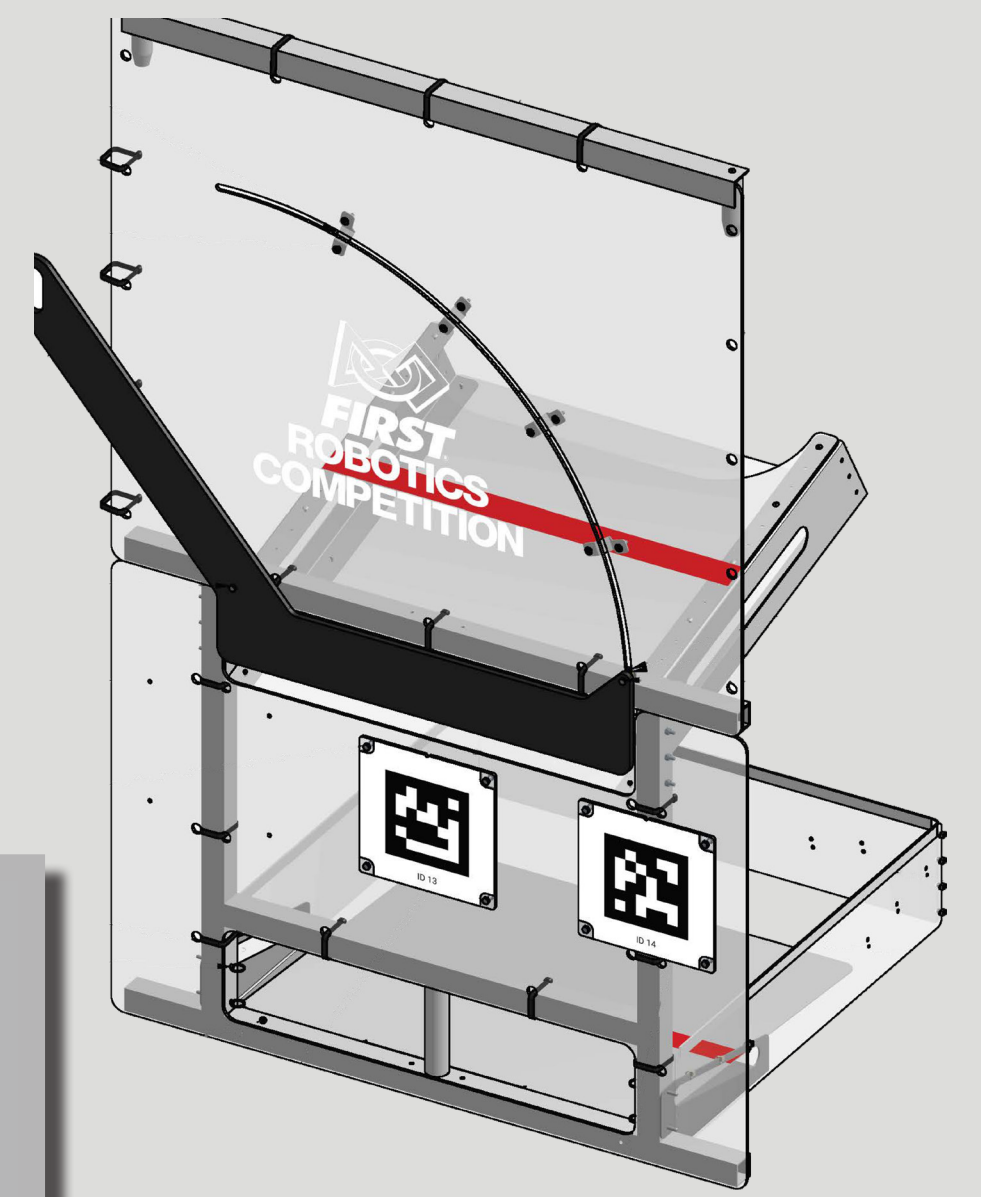

OUTPOST

TOWER

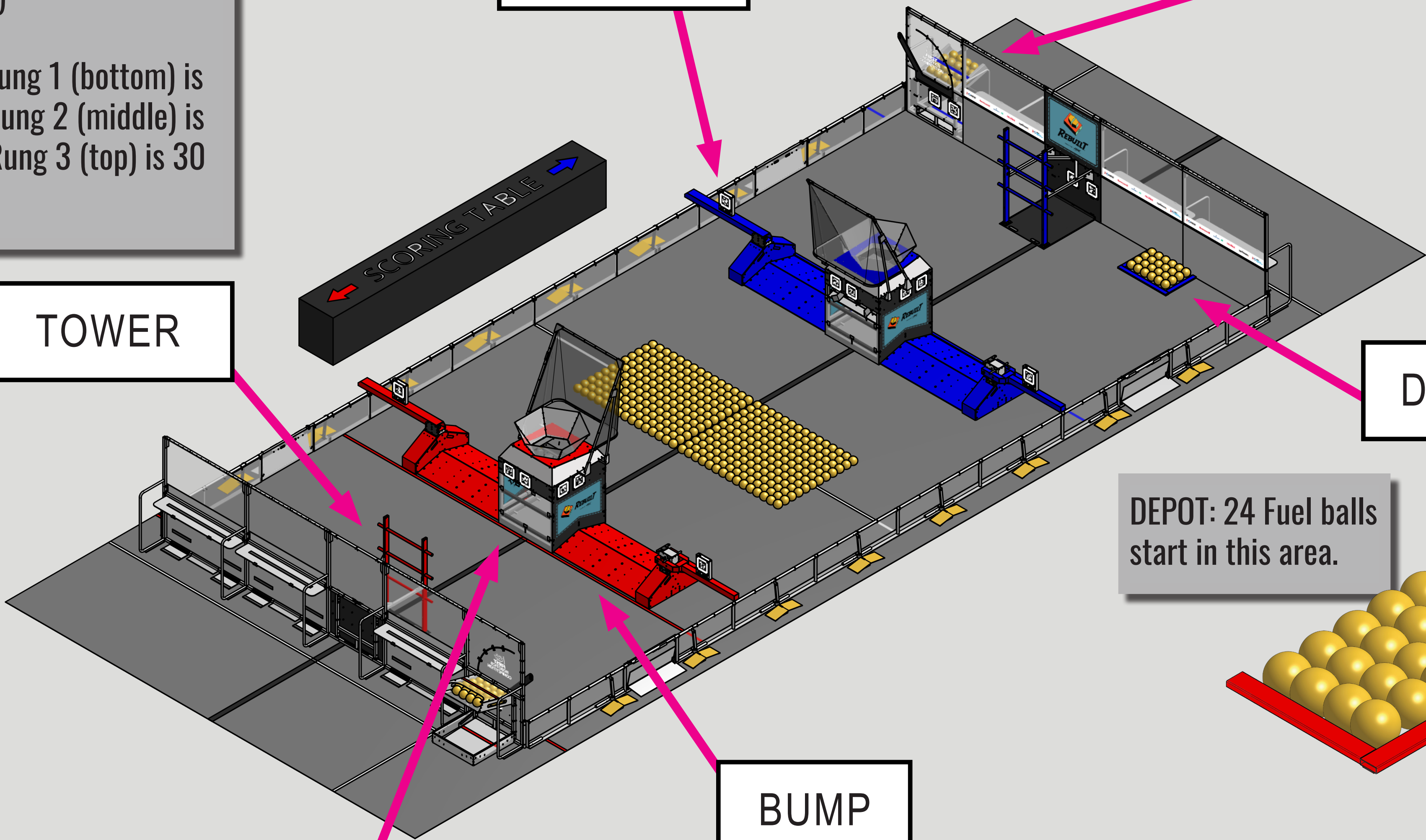

DEPOT

DEPOT: 24 Fuel balls start in this area.

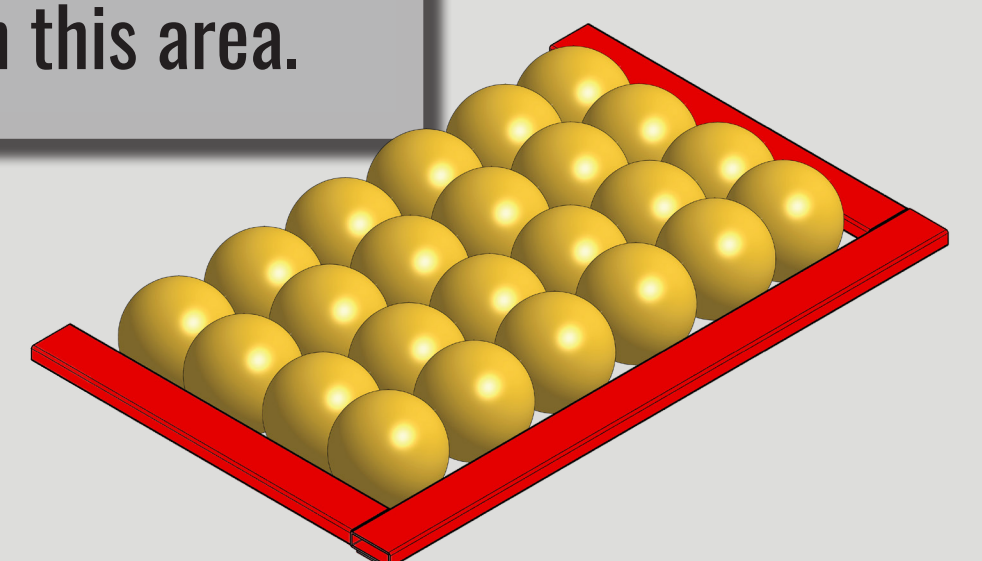

BUMP

BUMP: This is a 6" height at the middle that robots can drive over.

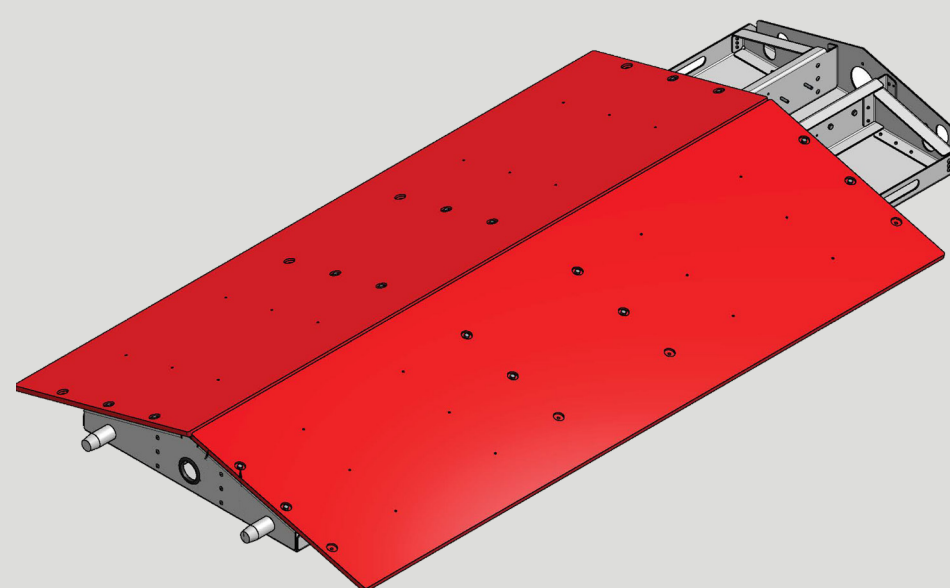

HUB

HUB: This is where Fuel will be shot into. Each Fuel Scored = 1 point

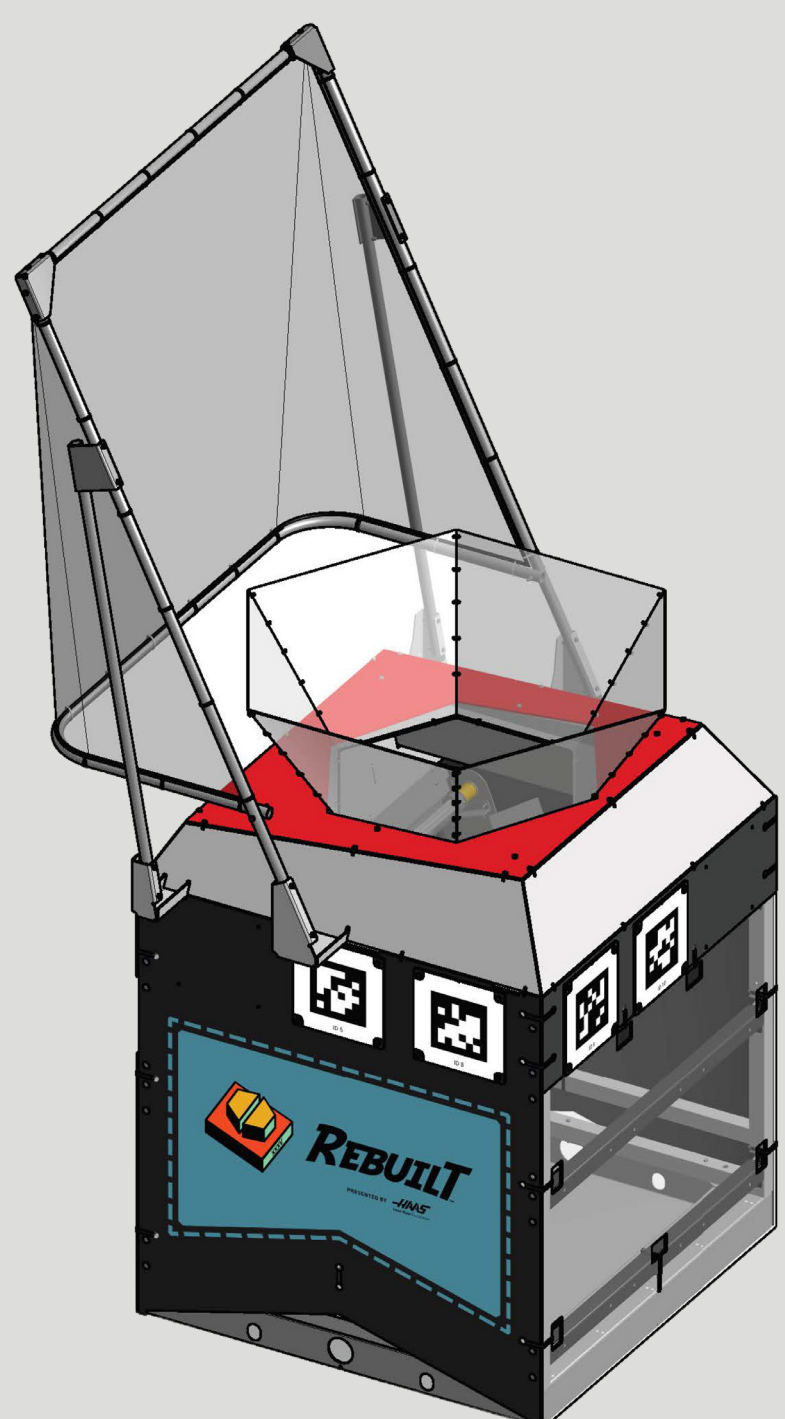

FUEL

FUEL: Each field ball in the hub is worth 1 point.

